

APPROVED

APR 20 2023

BOARD OF RECREATION AND PARK COMMISSIONERS

BOARD REPORT

NO. 23-080

DATE April 20, 2023

C.D. 14

BOARD OF RECREATION AND PARK COMMISSIONERS

SUBJECT: ARTS DISTRICT PARK – CANCELLATION OF ROTATING MURAL PROJECT – STATUTORY EXEMPTION FROM THE PROVISIONS OF THE CALIFORNIA ENVIRONMENTAL QUALITY ACT (CEQA) PURSUANT TO ARTICLE II, SECTION 2(j) [PROJECTS WHICH ARE REJECTED OR DISAPPROVED] OF CITY CEQA GUIDELINES AND ARTICLE 18, SECTION 15270 OF CALIFORNIA CEQA GUIDELINES

B. Aguirre M. Rudnick
C. Santo Domingo DE
B. Jackson N. Williams

[Signature]
General Manager

Approved X Disapproved Withdrawn

RECOMMENDATIONS

- 1. Cancel the ongoing rotating mural project, previously approved in Board Report 17-007, at Arts District Park and authorize the removal of the metal frame and plywood panels in connection with such mural project;
2. Determine that this action is statutorily exempt from the provisions of the California Environmental Quality Act (CEQA) pursuant to Article II, Section 2(j) [Projects which are rejected or disapproved] of City CEQA Guidelines and Article 18, Section 15270 of California CEQA Guidelines and direct Department of Recreation and Parks (RAP) staff to file a Notice of Exemption (NOE) with the Los Angeles County Clerk;
3. Authorize RAP's Chief Accounting Employee to prepare a check to the Los Angeles County Clerk in the amount of \$75.00 for the purpose of filing a Notice of Exemption (NOE); and
4. Authorize RAP's Chief Accounting Employee to make technical corrections as necessary to carry out the intent of this Report.

BOARD REPORT

PG. 2 NO. 23-080

SUMMARY

Arts District Park is located at 501 South Hewitt Street. This 0.50-acre pocket park includes a children's play area, performance space and a shaded picnic area.

On January 18, 2017, the Board of Recreation and Parks Commissioners (Board) approved the installation of an ongoing rotating mural project at Arts District Park per Report No. 17-007 (Attachment 1).

The project, spearheaded by the Office of Council District 14 and community partner Art Share L.A., entailed the installation of a metal frame attached to an existing concrete masonry wall. The frame holds five (5) plywood panels, each of which measure four by seven feet (4' x 7'). The project initially intended to rotate a different mural every six (6) months for a period of three (3) years. As stipulated in the Report, every subsequent mural would be required to go through a final approval process with RAP as well as requiring the artist to sign the Artist Waiver for Murals, Plaques and Public Art (Artist Waiver), a waiver of proprietary rights for artwork placed upon City Property. The inaugural mural installation, entitled "*Graffiti Spirit: an LA Renaissance*", was approved in Report No. 17-007 and installed in 2017. This mural remained displayed at Arts District Park until December 2022.

The former executive director of Art Share L.A. advised that the rotating mural program "fell flat" due to the Office of Council District 14's "constant upheaval".

RAP was advised that in January 2023, the Los Angeles River Artist and Business Association (LARABA) coordinated the removal of the inaugural mural and installed a new mural without RAP's permission. RAP staff was advised that this new artwork is not meant to be part of the rotating mural program.

RAP staff sent a notice to the artist and LARABA in February 2023 demanding that the mural be removed from Arts District Park. The process to get the unapproved mural removed from Arts District Park has proved to be extremely complicated, with the party initially refusing to comply with RAP's demands to remove their mural and instead trying to circumnavigate RAP entirely and get it approved by other means. Since the party never submitted the required Public Art Application or a signed Artist Waiver, RAP is limited in its right to promptly remove the mural under the California Art Preservation Act (CAPA) of 1979 and the federal Visual Artists Rights Act (VARA) of 1990, despite it being an unapproved piece of art on City property.

RAP is currently working with LARABA as well as the artist to remove the mural, separate from the recommendation(s) in this report.

Due to the failure of this rotating mural program to move forward as conceptualized and the difficulties RAP has encountered with regards to the unauthorized use of the property, it is recommended that the Board cancel the rotating mural program and authorize the removal of the accompanying metal frame and plywood panels that were installed as part of the project.

BOARD REPORT

PG. 3 NO. 23-080

Any future public art installation for Arts District Park will be subject to RAP's Public Art Policy and procedures and will be presented to the Board for approval.

ENVIRONMENTAL IMPACT

The proposed Project consists of the disapproval of a project.

Staff recommends that the Board determines that it is statutorily exempt from the provisions of the California Environmental Quality Act (CEQA) pursuant to Article II, Section 2(j), of City CEQA Guidelines and Article 18, Section 15270 of California CEQA Guidelines. RAP staff will file a Notice of Exemption with the Los Angeles County Clerk upon Board's approval.

FISCAL IMPACT

The approval of this Report will have no fiscal impact on RAP's General Funds.

This Report was prepared by Robert Eastland, Management Assistant, Planning, Maintenance and Construction Branch.

ATTACHMENTS

- 1) Attachment 1 – Board Report No. 17-007

APPROVED
01-18-2017
**BOARD OF RECREATION
AND PARK COMMISSIONERS**

BOARD REPORT

NO. 17-007

DATE January 18, 2017

C.D. 14

BOARD OF RECREATION AND PARK COMMISSIONERS

SUBJECT: ARTS DISTRICT PARK - INSTALLATION OF A MURAL PROJECT;
CATEGORICAL EXEMPTION FROM THE CALIFORNIA ENVIRONMENTAL
QUALITY ACT (CEQA), PURSUANT TO ~~ARTICLE VII~~,* SECTION 1, CLASS 1 (1) *ARTICLE III
OF THE CITY CEQA GUIDELINES (MODIFICATIONS OF AN EXISTING PARK
FACILITY WITH NO EXPANSION OF USE)

AP Diaz

V. Israel

for *R. Barajas

CSD

N. Williams

H. Fujita

Ramon Barajas for

General Manager

Approved

Disapproved

Withdrawn

As Amended

RECOMMENDATIONS

1. Approve the installation of an ongoing rotating mural project at Arts District Park;
2. Authorize the Department of Recreation and Parks (RAP) staff to issue the appropriate Right-of-Entry (ROE) permit;
3. Find that the Project is categorically exempt from the California Environmental Quality Act (CEQA) pursuant to ~~Article VII~~,* Section 1, Class 1(1) of the City CEQA Guidelines, and *Article III direct RAP staff to file a Notice of Exemption; and
4. Authorize RAP's Chief Accounting Employee to make technical corrections as necessary to carry out the intent of this Report.

SUMMARY

Arts District Park is a new 0.50 acre park located at 501 South Hewitt Street within the Arts District community of downtown Los Angeles. This pocket park includes a children's play area, performance space and picnic area.

During the public participation phase of the development of Arts District Park, the community communicated the need for the park to incorporate design elements that reflect the unique character of the Arts District. In response, RAP staff has worked closely with the Office of Councilmember Jose Huizar, Fourteenth Council District, and community partner Art Share L.A.

BOARD REPORT

PG. 2 NO. 17-007

on the development of an ongoing and rotating mural project. This Project proposes the installation of a metal frame attached to an existing concrete masonry wall. The frame will hold five (5) plywood panels, each of which measures four by seven feet (4'x7'). The panels will be painted by muralists selected through a community process with their respective mural on display for an average of six (6) months. There are anticipated to be six (6) such selection processes, which will provide for a rotation of original mural artwork for approximately three (3) years. Each of the murals will become the property of RAP to ensure that the park retains flexibility of mural rotation and each muralist will be required to sign the Artist Waiver for Murals, Plaques and Public Art (Waiver), a waiver of proprietary rights for artwork placed upon City property.

The hanging panel method of installation facilitates the removal of any mural that becomes defaced.

The artist selected for the inaugural mural is Alex Poli, AKA Man One. Man One is a veteran of the Arts District community with extensive experience creating public art throughout Los Angeles. This mural, *Graffiti Spirit: an LA Renaissance*, was selected through a public participation voting process at the grand opening of Art District Park and Mr. Poli has submitted a signed Waiver for this work. A depiction of the mural *Graffiti Spirit: an LA Renaissance* and a description of the subsequent mural selection process is attached hereto as Exhibit A. Subsequent murals which comply with the selection process will be presented to the Facility Repair and Maintenance Commission Task Force for final approval.

ENVIRONMENTAL IMPACT STATEMENT

The proposed project involves the installation of framed panels on a wall of an existing park facility for the purpose of displaying public art by various artists that are periodically rotated. This will not result in any expansion of the use of the Arts Park facility. Therefore, Staff recommends that the Board determine that the subject project is categorically exempt from the provisions of the California Environmental Quality Act (CEQA) pursuant to ~~Article VII~~,^{*} Section 1, Class 1 (1) of the City CEQA Guidelines. A Notice of Exemption will be filed with the Los Angeles County Clerk within five (5) working days of the Board's approval. *Article III

Council District 14 and RAP management and staff support this project at Arts District Park.

FISCAL IMPACT STATEMENT

There will be minimal fiscal impact to RAP as RAP is only responsible for assisting with installation and routine maintenance. Costs of the mural creation, installation, and anti-graffiti coating will be the shared responsibility of Council District 14 and Art Share LA.

This Report was prepared by Melinda Gejer, City Planning Associate, Planning, Construction and Maintenance Branch.

BOARD REPORT

PG. 3 NO. 17-007

LIST OF ATTACHMENT(S)

- 1) Exhibit A – Artist Selection Process

ARTS DISTRICT PARK

Mural Rotation Project

Artist Selection Process

1. Artist selection begins with an Open Call for Artists by Art Share L.A. The Open Call for Artists reaches approximately 2,000 local artists in Los Angeles and describes the project parameters as well as desired qualifications in the artists.
2. Art Share L.A. gathers the submissions and forms a selection committee to choose the top five mural designs. The selection committee includes, at a minimum, a community representative from Los Angeles River Artists & Business Association (LARABA), a representative from a local homeowner association, an Art Share L.A. staff member, and an employee from the Department of Recreation and Parks.
3. The top five designs will be shared on social media to facilitate community participation in the voting process.
4. The winning mural will be presented to the Department of Recreation and Parks Facility Repair and Maintenance Task Force for final approval.
5. Art Share L.A. will visit various community meetings to announce the new design and installation details, inviting community participation in each unveiling.

Arts District Park Mural Proposal

...

Alex AKA Man One

A

Man One

An artist, curator, mentor and entrepreneur, Man One believes in the transformational power of art and its power to save lives and make the world a better place.

Growing up in Los Angeles, Man One developed his love for art, developing his skills as a graffiti artist on the streets of LA. He honed his talents as a fine artist and understanding of art history at Loyola Marymount University where he earned his Bachelor's Degree in Fine Arts.

Man One is seen as a staple in Los Angeles, San Gabriel Valley graffiti. His images are recognizable and celebrated by many Angelenos.

Man One - Colorful Iconic Imagery



Man One



Arts District Park



Arts District Park will bring the community together. By rotating the mural on a 6 month basis, the park can see many different colors and themes.

With the inaugural mural, ManOne embodies the Arts District by paying homage to past populations and the budding art scene.

Concept (similar mural in color)



Concept (sketched)



“Graffiti of L.A. Renaissance”

There's lots of symbolism but in a nutshell; the winged serpent (my version of a modern Quetzalcoatl & god of the arts) has its hands on the tools that created the Arts District (brushes & spray cans) its wings and halo also represent the City of Angels and how it's currently balancing all its weight on one hand. Underneath the spirit is the landscape of the Arts District, shown by the buildings & new bridge in the background.

-Man One

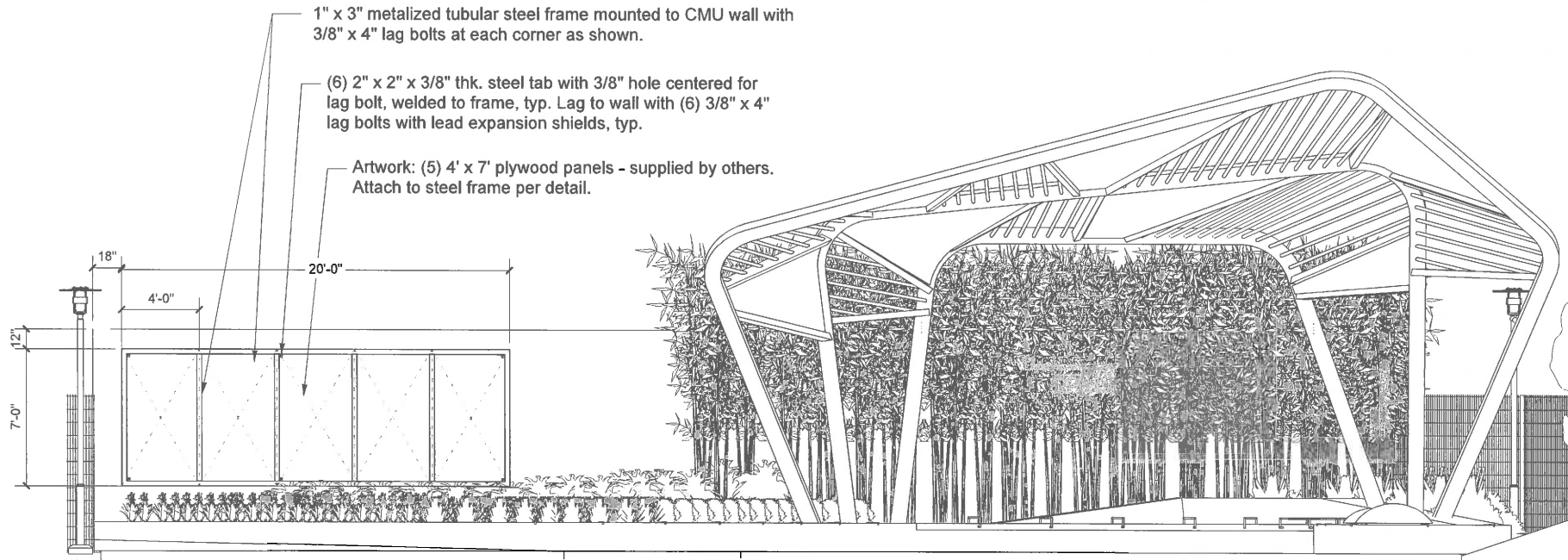

ARTS DISTRICT PARK - CMU WALL MURAL FRAME

SCALE: 3/16" = 1' 0"

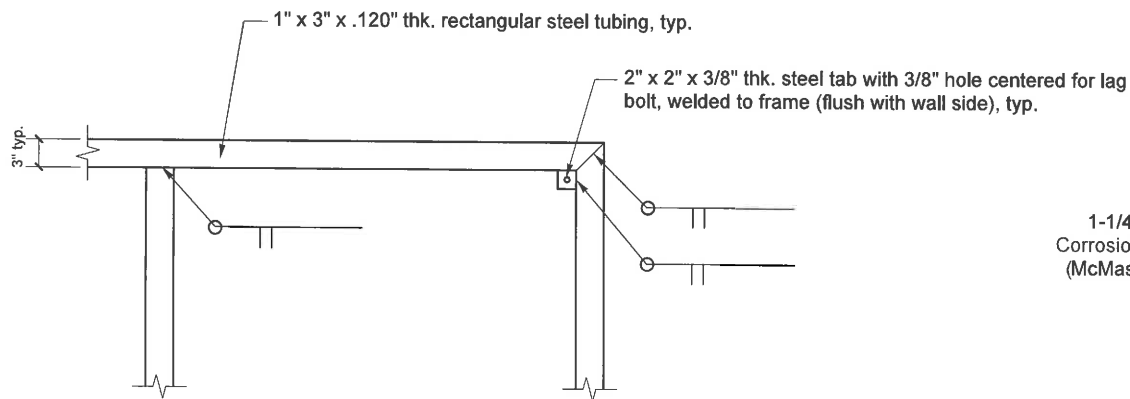

- Notes:
- 1.) Grind all welds smooth.
 - 2.) Steel tube frame shall have metalized finish.

STEEL FRAME WELDING & FINISH
N.T.S.

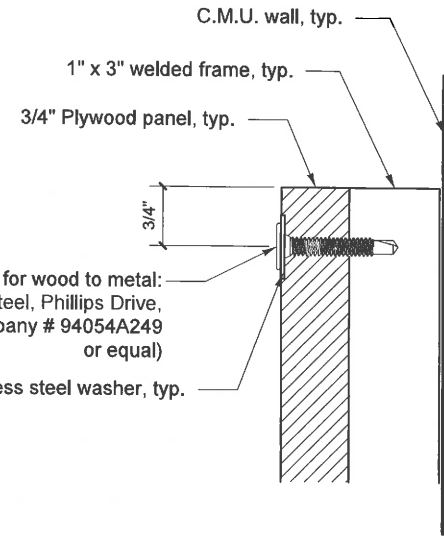

SECTION - ATTACHMENT OF PLYWOOD PANELS
N.T.S.

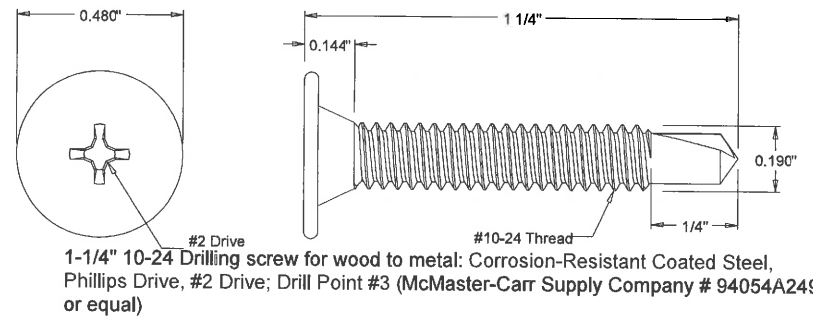

ARTS DISTRICT PARK - CMU WALL MURAL MOUNTING
N.T.S.